

Extended Right Angle Collet Grinders

320RAD Series



320RADK;20000;1/4

420RAD Series



420RADSK;13000;1/4

420RADRS;13000;1/4

RIGHT ANGLE GRINDERS

Exhaust Direction	Lever Style	MODEL NUMBER	Exhaust Direction	Lever Style	MODEL NUMBER
Side	Standard Lever	320RAD;20000;1/4	Side	Standard Lever	420RADS;13000;1/4
	Safety Lever	320RADK;20000;1/4		Safety Lever	420RADSK;13000;1/4
Rear	Standard Lever	320RADR;20000;1/4	Rear	Standard Lever	420RADRS;13000;1/4
	Safety Lever	320RADRK;20000;1/4		Safety Lever	420RADRSK;13000;1/4

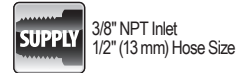
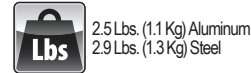
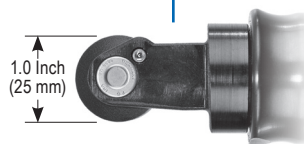
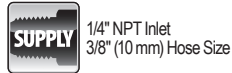
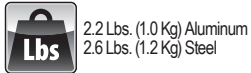
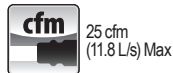
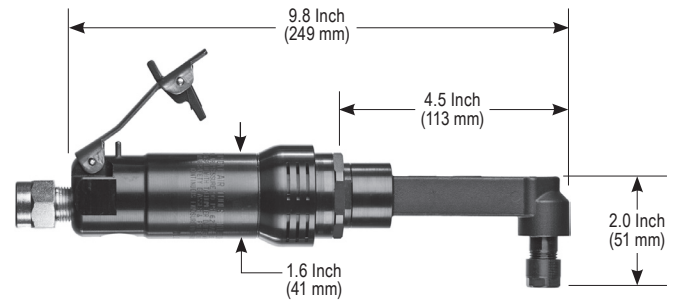
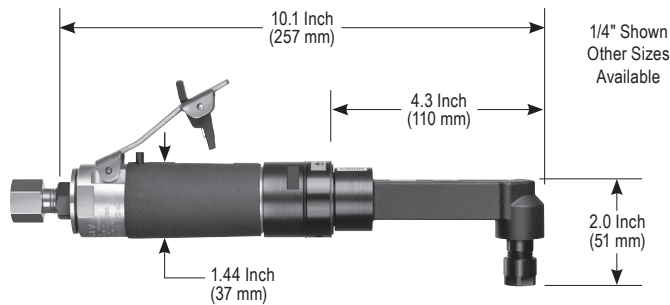

STANDARD EQUIPMENT

- Tool
- Operating Instructions and Service Manual
- Wrenches (sizes based on options)



The ER Heavy Duty Collet is Standard Equipment on 320RAD & 420RAD Series.

320RAD Alternate Options

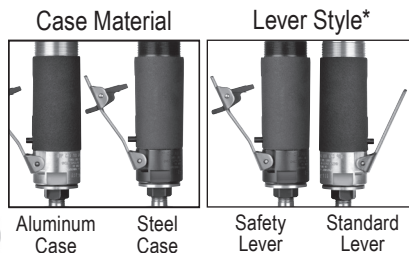

420RAD Alternate Options

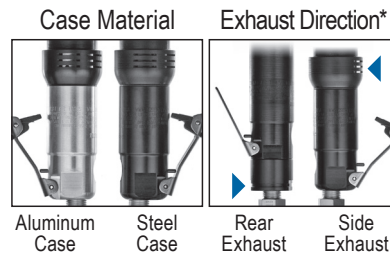

Abrasive Mounting



*APPLIES TO BOTH TOOL SERIES